

HC - HCD series

5-10B / PLAIN TUBE TYPE 清水用

TYPE : HC-***P*

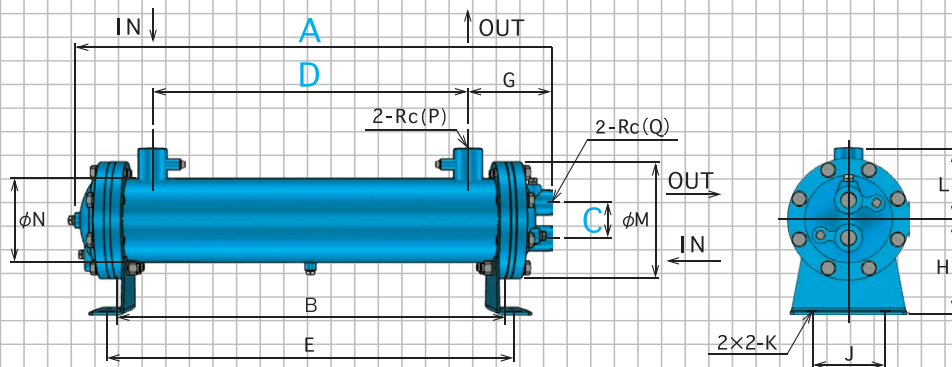

TYPE : HC-***F*

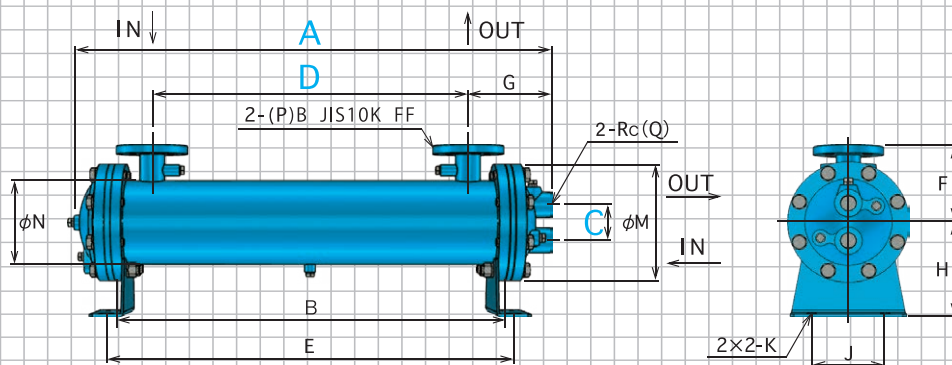

TYPE : HCD-***F*

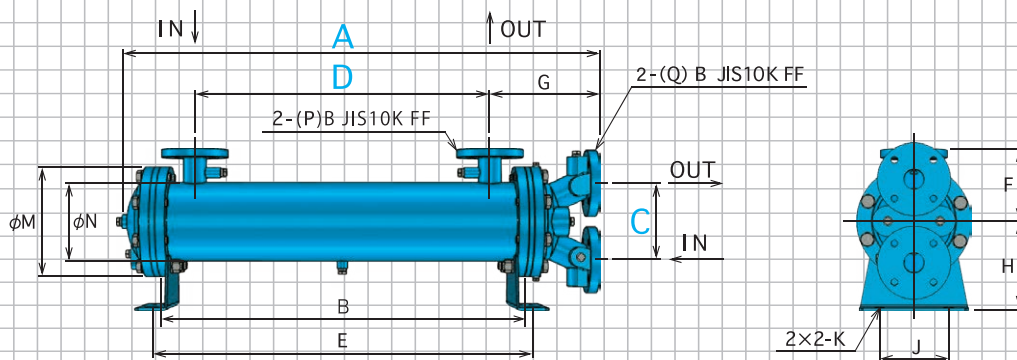

SIZE

最高使用圧力 | 胴側 : 0.98MPaG 管側 : 0.49MPaG | 標準塗装色 | メタリックブルー
 Max. working pressure | Shell side : 0.98MPaG Tube side : 0.49MPaG | Standard paint color | Metallic blue

SPEC

|条件| 流体：ISO VG32相当 油入口温度：65℃ 水入口温度：30℃
 |Condition| Fluid：ISO VG32 equivalent. Oil inlet temperature：65℃ Water inlet temperature：30℃

TYPE		A	B	C	D	E	F	G	H	J	K	L	M	N	P	Q	質量 (kg)	伝面 (m ²)
HC HCD	510	739 789	602	65 150	460	616	140	153 203	160	120	18x25	120	195	139.8	11/4	3/4 1 1/4	38	0.83
	512	849 899	712		570	726											41	
	514	964 1014	827		685	841											44	
	516	1084 1134	947		805	961											54	
	518	1194 1244	1057		915	1071											47	
	520	1319 1369	1182		1040	1196											57	
HC HCD	620	922 982	760	70 160	620	784	150	126 222	180	140	18x30	140	230	165.2	11/2	1 1 1/2	59	1.61
	623	1032 1092	870		735	894											63	
	625	1102 1162	940		805	964											75	
	627	1177 1237	1015		880	1039											65	
	630	1282 1342	1120		985	1144											77	
HC HCD	840	1065 1135	866	100 200	720	888	180	185 255	200	160	22x35	160	280	216.3	2	1 1/4 2	120	3.27
	850	1265 1335	1066		920	1088											135	
	860	1465 1535	1266		1120	1288											145	
	870	1685 1755	1486		1340	1508											140	
	880	1895 1965	1696		1550	1718											155	
HC HCD	1080	1160 1240	946	120 220	780	968	220	205 285	250	200	22x35	210	340	267.4	2 1/2	1 1/2 2 1/2	180	6.99
	1090	1280 1360	1066		900	1088											195	
	10100	1390 1470	1176		1010	1198											205	
	10120	1630 1710	1416		1250	1438											230	
	10140	1870 1950	1656		1490	1678											255	
	10160	2110 2190	1896		1730	1918											280	

単位：mm



- ※HCD-10シリーズは胴側取合フランジタイプのみ。
- ※Shell side connection of HCD-10 series is flange type only.
- ※性能グラフはHCシリーズと同様。
- ※The performance curve is the same as HC series.

SPEC

条件 | 流体 : ISO VG32 相当 油入口温度 : 65°C 水入口温度 : 30°C
 Condition | Fluid : ISO VG32 equivalent. Oil inlet temperature : 65°C Water inlet temperature : 30°C

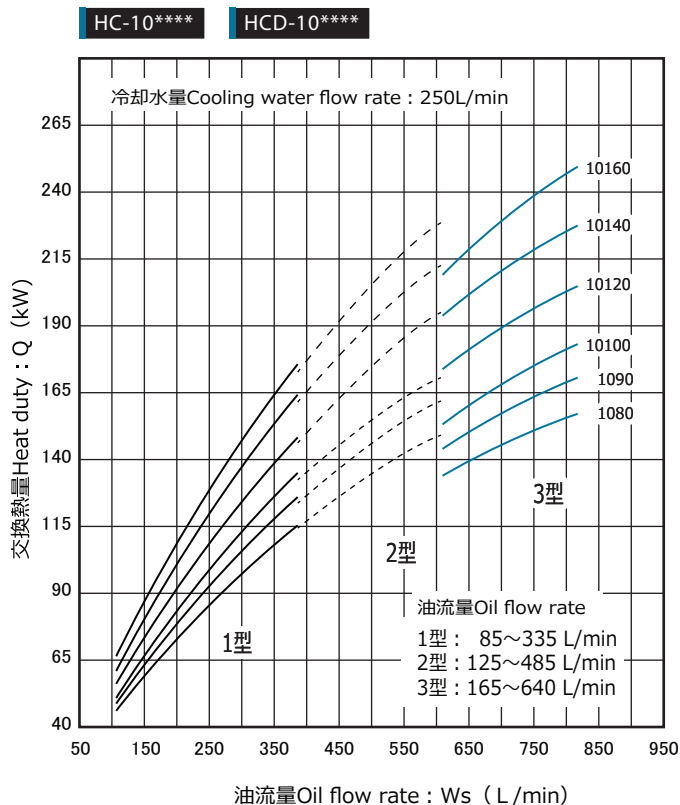
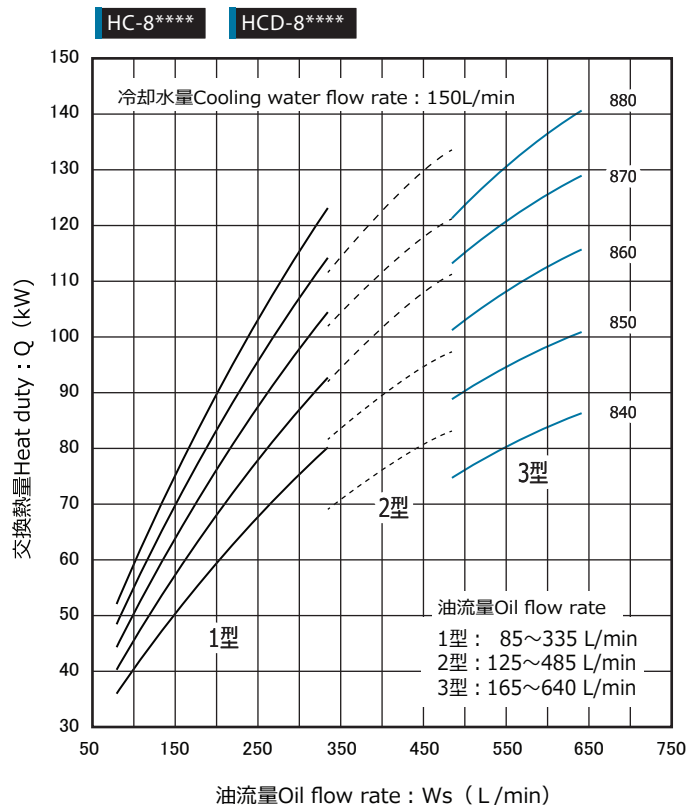
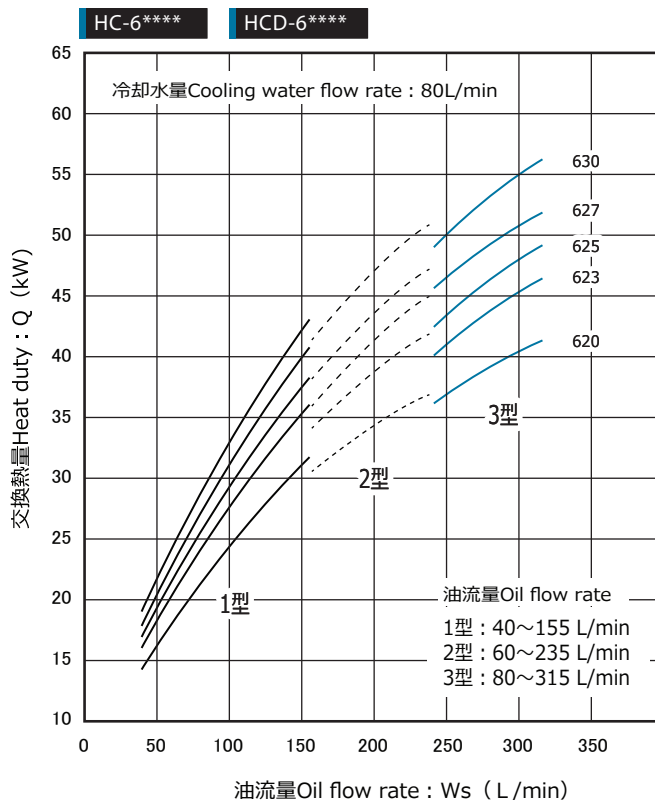
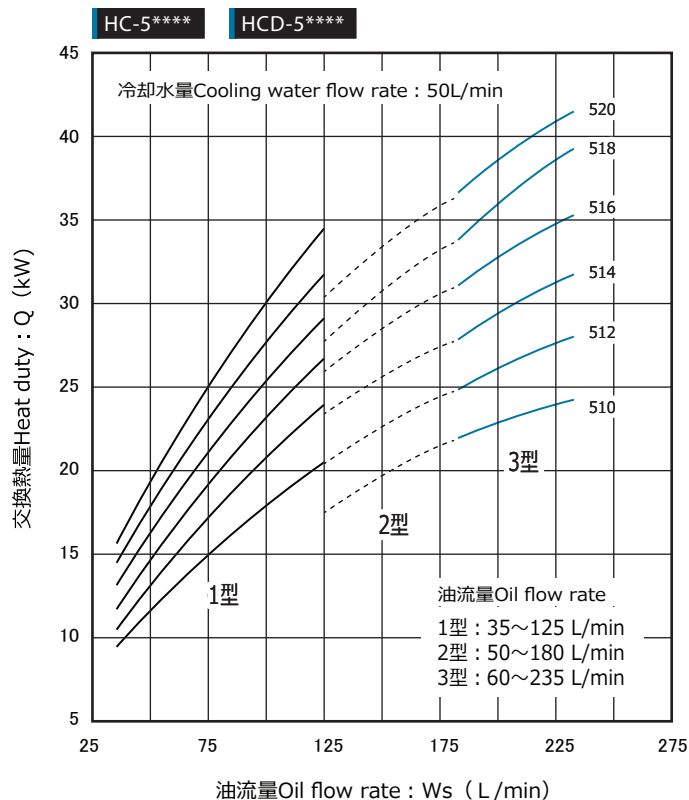

※ 上記と異なる条件でご使用の場合はP 24 の『選定仕様書』を正確に記入の上、弊社までご連絡ください。

※ In use of different conditions from the above, please accurately fill in "SPECIFICATION SELECTION" on page 25 and contact us